



HAZEMAG Roller Screen | HRS
HAZEMAG VARIOwobbler® | HWV



HRS | HAZEMAG Roller Screen – sturdy and effective screening

In recent years conventional roller screens proved more and more successfully as sturdy and effective equipments for the screening of fines in the feed material of crushing plants.

At a roller screen the separation surface is formed by rotating disc-fitted rollers, which transport the material, circulate and loosen it. The separation of the fines is effected in the gap between the individual rollers whilst the coarse material is transported via the screen into the overflow. The polygonal shape of the discs supports the material conveyance.

Especially in case of difficult to screen bulk material (moist material with loamy or argilla-ceous shares) this kind of screening distinctly outclasses the oscillating screening machines, which frequently show baking and adhesions with these materials. Adhesions due to the movement in the separation surface and the resulting self-cleaning properties do not occur at roller screens. In addition, each roll has scraper elements for a guaranteed cleaning.

Furthermore the downstream crusher is relieved through a roller screen which obviously results in reduced wear, a reduced energy consumption and – at best – in using a smaller crusher. In general roller screens entail reduced energy and operational costs and/or an increased operational reliability.

Transporting the material is effected horizontally so that the subsequent crusher is fed gently and constantly.

The compact design, resulting from the horizontal material flow, as well as a multitude of options permit the application in many ranges – above as well as underground. Plants of this type are suited for

different operations in limestone, clay stone, coal, natural stone, salt, gypsum and other materials.

The HAZEMAG roller screen HRS is available as a one or multi-stage device as well as with a variable gap setting, thus meeting all customer requirements. Due to a modularization of the roller screen length almost any sizes of separation surfaces may be realized.





HAZEMAG **VARIOwobbler**® | HVW – eminently adaptable roller screen

The HAZEMAG **VARIOwobbler**® HVW constitutes the new generation of roller screens. Its distinctive feature is that the gap setting between the individual shafts and thus the separation is infinitely adjustable at the push of a button and without any tools.

This leads to a distinct extension of the field of application and a solid increase of flexibility by being able to very quickly respond to changing requirements and permitting a permanently correct adjustment of the roller screen.

The distance between the individual shafts is infinitely adjusted by a mechanic-hydraulic system. In the front part of the machine the roller distance is fixed in most cases at the smallest required gap, whilst the rear part is correspondingly adjustable. This permits to respond very flexibly to changing input, market and operational requirements.

Under difficult raw material conditions, such as high levels of contamination, the flexibility of the scalping system can be enhanced and easily fulfilled by the HAZEMAG **VARIOwobbler**® HVW Roller Screen; which offers hydraulic gap setting adjustment. The benefits of the **VARIOwobbler**® are easily realized, especially when the raw material contains a high level of variations. Taking everything into account, pre-screening and the utilization of the **VARIOwobbler**® can provide the operating company with a very high level of operating benefits; increased product quality and reduced operating costs.

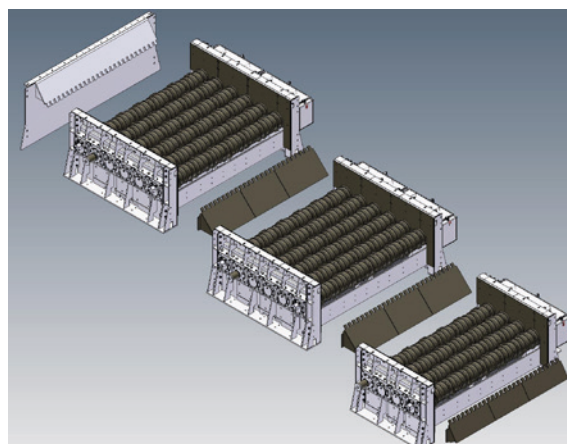
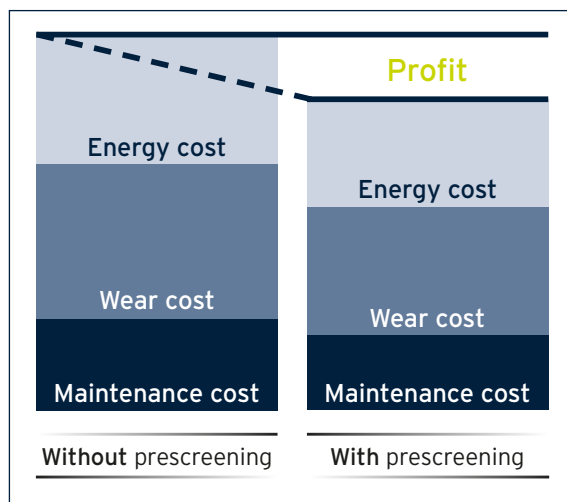

Roller screen modules with four and six shafts





HRS | HAZEMAG Roller Screen – sturdy and effective screening

HAZEMAG HRS HVW				
Type*	Width [Inch]	max. capacity** [t/h]	max. feed lump volume [vd³]	max. edgelenlength of lump [Inch]
HRS / HVW 10xx	39.4	330	0.4	31.5
HRS / HVW 13xx	51.2	771	0.7	39.4
HRS / HVW 16xx	63.0	1,322	1.7	47.2
HRS / HVW 20xx	78.7	1,930	2.4	55.1
HRS / HVW 24xx	94.5	2,480	2.7	59.0
HRS / HVW 26xx	102.4	2,800	3.3	67.0

* available in different length | ** values are variable and can be aligned to the particular requirements

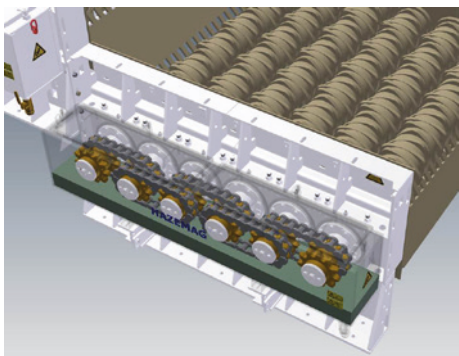
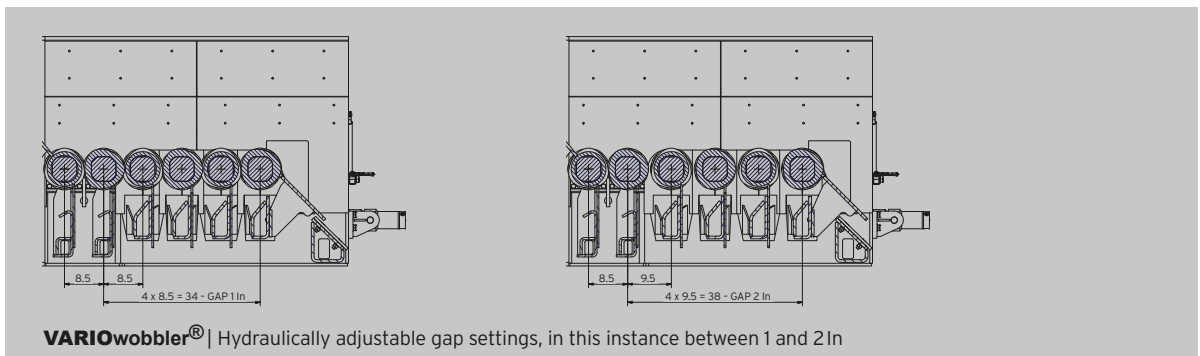

Chain drive system